



PROOFCERT
TEST THE IMPOSSIBLE

21st Century Testing Equipment!

ADVANCED PULL TEST SYSTEMS
SYSTEM UPGRADES
INNOVATIVE TOOLING DESIGNS
HORIZONTAL AND VERTICAL SOLUTIONS
CUSTOM TESTING MACHINE SOLUTIONS
LOAD MONITORING EQUIPMENT
TENSION LINK LOADCELLS (LMS)

WIRE ROPE GRIPS



- WEDGE TYPE WIRE ROPE GRIPS CAN BE CONFIGURED FOR ALMOST ANY EXISTING TESTING MACHINE.
- THIS TYPE OF ROPE GRIP IS IDEAL FOR TESTING LARGER ROPE DIAMETERS OF MANY SIZES.
- VARIOUS MOUNTING CONFIGURATIONS ARE ALSO AVAILABLE DEPENDING ON YOUR PRODUCTION NEEDS.
- INTERCHANGEABLE INSERTS PERMIT TESTING OF IMPERIAL AND METRIC ROPES.

- CAPSTAN TYPE ROPE GRIPS PROVIDE INCREASED PRODUCTION WHEN TESTING SMALLER ROPES.
- THESE ARE DESIGNED TO TEST ROPES UP TO 3/4" (20MM) AND CAN BE CUSTOM FIT TO WORK WITH THE SMALLER AXIS ON MOST EXISTING MACHINES.
- THESE UNITS QUICKLY ADJUST TO ACCOMMODATE VARIOUS SIZE ROPES BY ADJUSTING A FEW SLIP IN SHIMS.



MADE IN THE
USA

PO BOX 306
EDEN, GA 31307
WWW.PROOFCERT.COM

PH. 912-964-9465
FAX. 912-823-4317
EMAIL. charles@proofcert.com





PROOFCERT
TEST THE IMPOSSIBLE

21st Century Testing Equipment!

**EASILY ADJUSTABLE
ECONOMICAL SOLUTION
VARIOUS MOUNT CONFIGURATIONS
INSERT STORAGE RACK WITH EACH UNIT
STRUT ACTUATED CLAMPING ARRANGEMENT
HYDRAULIC CLOSURE OPTIONAL
WEDGE AND CAPSTAN TYPES AVAILABLE**

WIRE ROPE GRIPS

WEDGE TYPE

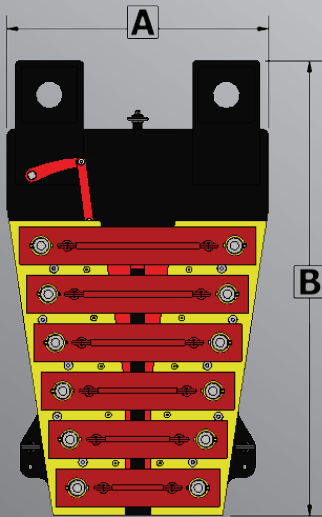

SPECIFICATIONS					
MODEL	CAPACITY (lbf)	STANDARD INSERTS	A	B	WT (lbs)
1.5"	150K	8 SIZES (.38" to 1.25")	21.125"	27.25"	623
2"	250K	11 SIZES (.38" to 1.75")	23.000"	36.25"	1056
2.5"	350K	13 SIZES (.38" to 2.25")	28.125"	48.75"	1361
3"	400K	14 SIZES (.38" to 2.75")	28.125"	48.75"	1361
3.5"	450K	SOLD SEPARATELY	38.500"	80.00"	2600*
4.5"	800K	SOLD SEPARATELY	38.500"	80.00"	2600*

* WEIGHT IS APPROXIMATE

- ON-SITE SETUP AND TRAINING AVAILABLE
- INSERTS ARE AVAILABLE IN METRIC AND IMPERIAL SIZES
- CAN BE SECURED INSIDE OR OUTSIDE THE BED
- FREE INSERT STORAGE RACK WITH EVERY UNIT

CAPSTAN TYPE

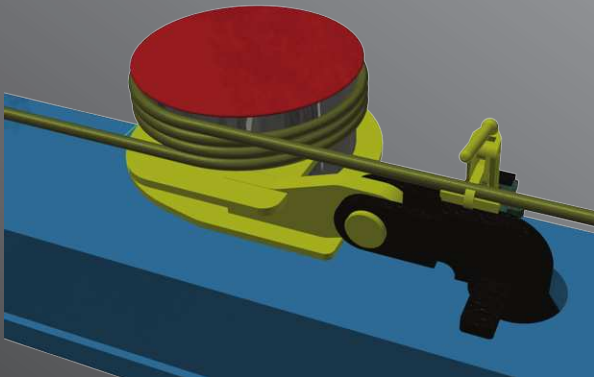

- CUSTOM MOUNTS AVAILABLE FOR YOUR EXISTING BED
- QUICKLY ADJUSTS TO DIFFERENT SIZE ROPES (1/4" TO 5/8")
- RIGHT OR LEFT HAND CONFIGURATIONS AVAILABLE
- 30.5" LONG X 19" WIDE X 8.25" TALL
- SIMPLE SLIP IN SHIM ADJUSTMENT FOR DIFFERENT SIZE ROPES
- QUICK SETUP ON YOUR SMALLER TESTING AXIS
- HEAVIEST PIECE IS 56 LBS

CALL US TODAY FOR ANY OF YOUR TESTING EQUIPMENT OR CALIBRATION NEEDS

MADE IN THE
USA

PO BOX 306
EDEN, GA 31307
WWW.PROOFCERT.COM

PH. 912-964-9465
FAX. 912-823-4317
EMAIL. charles@proofcert.com

